

Eliyahu Goldratt

TOC

April 29, 2005

Jin-Ho Jeong, Ph.D.

Competitiveness Valuation International, Inc.

Korea Partner of IMD WCY

jeong@cvikorea.net

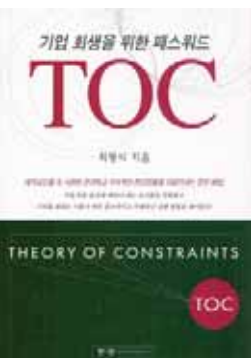

Eliyahu Goldratt



- 1948
- TOC (Theory of Constraints :
)
- The Goal() 1984
가 .
7,000
- H
- TOC



2. TOC

April 29, 2005

Jin-Ho Jeong, Ph.D.

Competitiveness Valuation International, Inc.

Korea Partner of IMD WCY

jeong@cvikorea.net

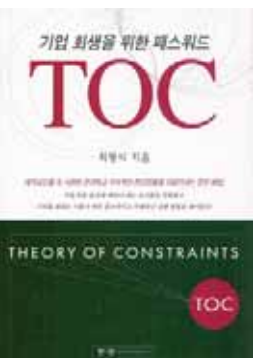

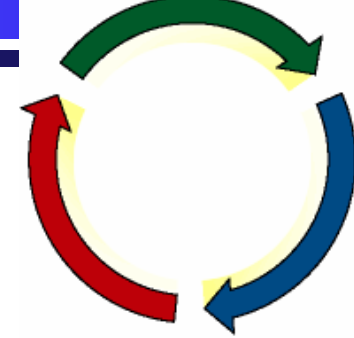

● TOC

;

● TP(Thinking Process) (Tree)

● TP



가

가(what to change)

가(what to change to)

가(hot to cause the change)

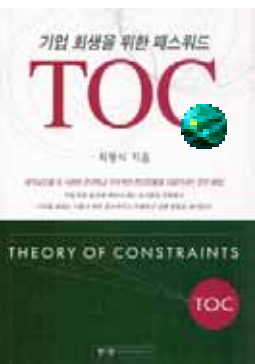

TP

가

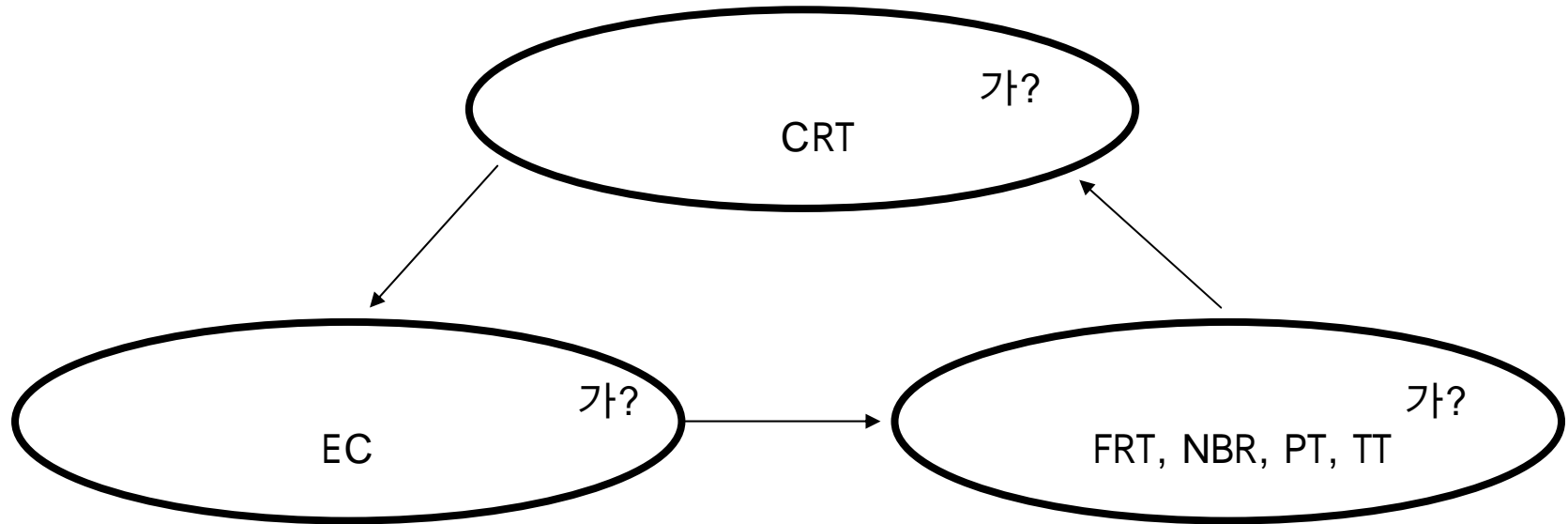

가



 **CRT** (Current Reality Tree ;

 가 ' (UDE ; UnDesirable Effects)

 **CRT** Cause-Effect),



가

가

CRT

CRT

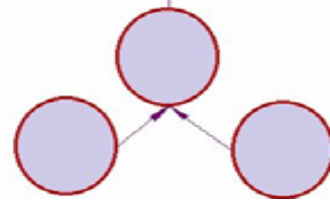

ECE(Effect-

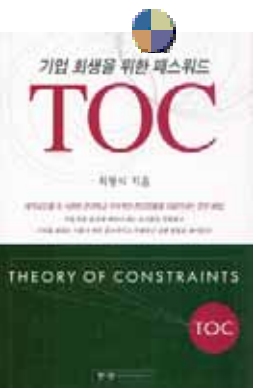

CRT



가

가

가

,

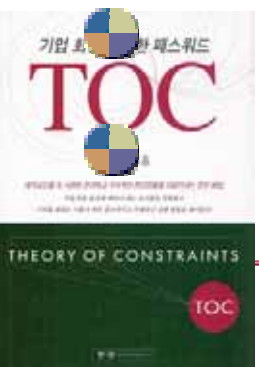



TP

가



CRT

가

가



가

,

가



CRT

,

,

,

가가

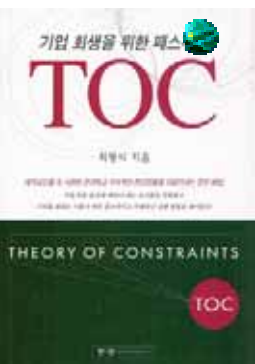

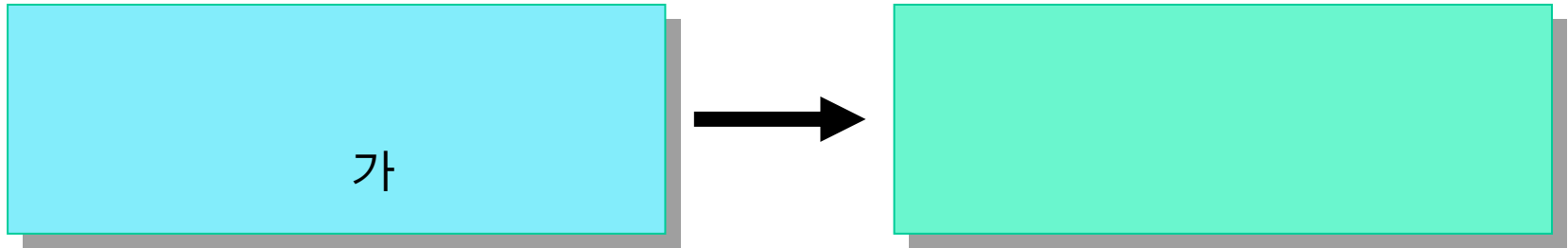

가

가

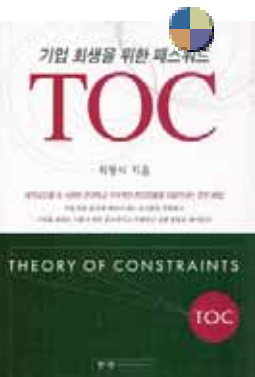

CRT

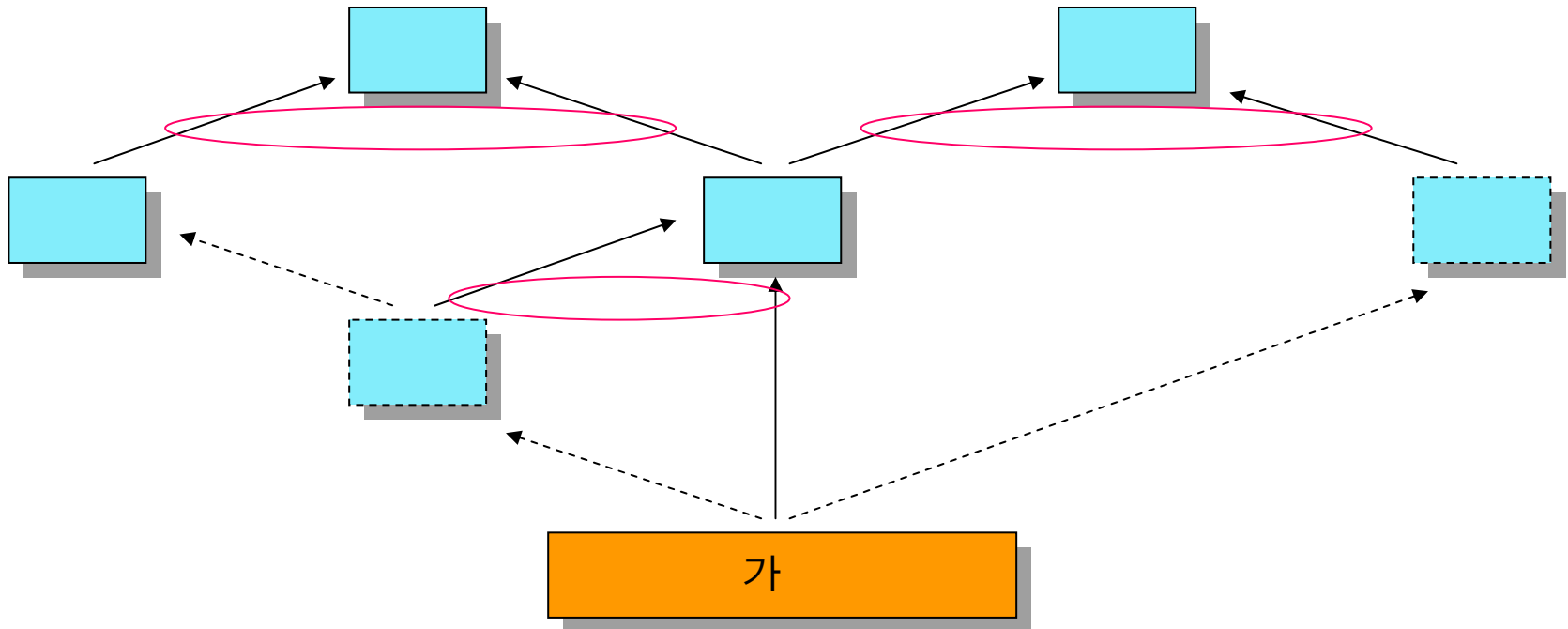

70%

가

(UDE ; UnDesirable Effects) :

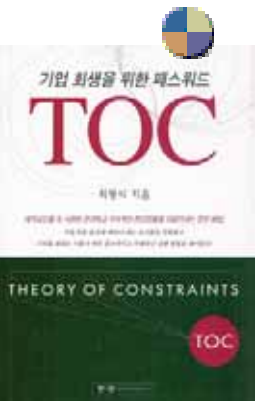

1.

" 가

가?"

2.

" 가

가?"

3.

" 가

가?"

4.

"

가

가?"

5.

"

가?"

"

가

가?"

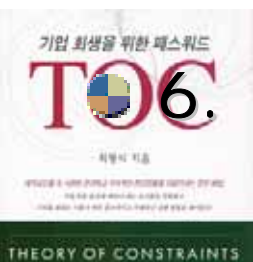
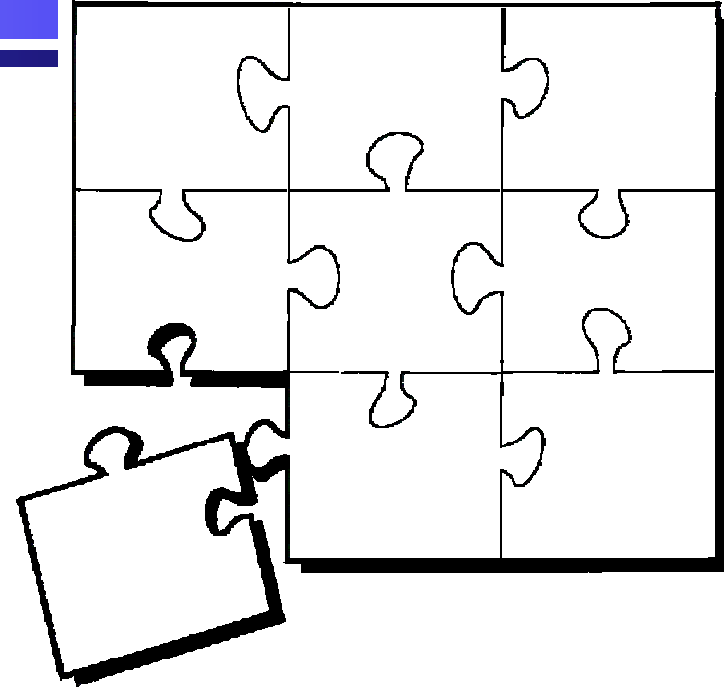

가

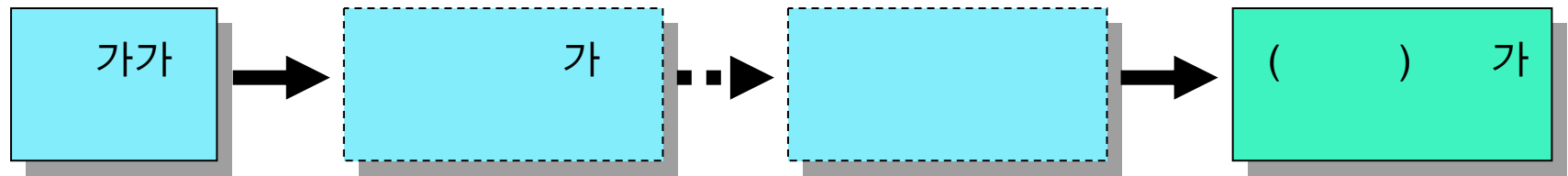

가 가 () 가 () , 가
() 가 ()'

가 , 가 가 가
가 가 가

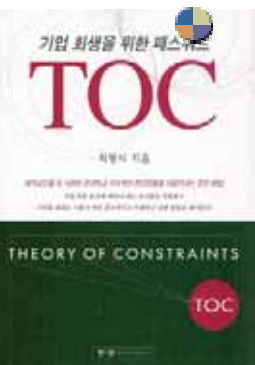

가

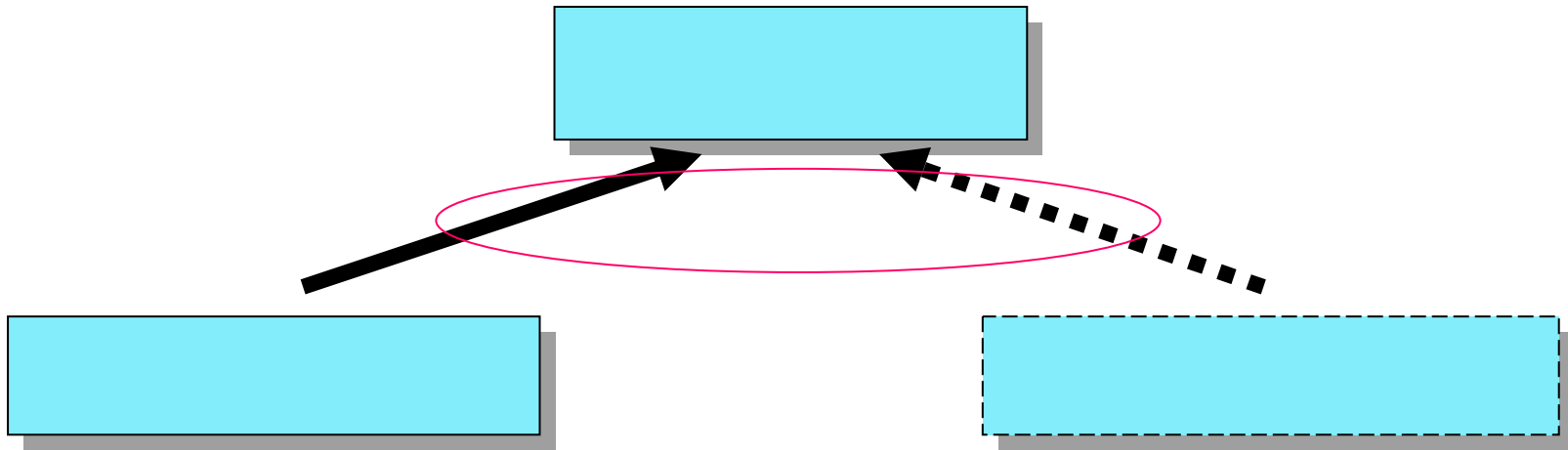

3

가

가

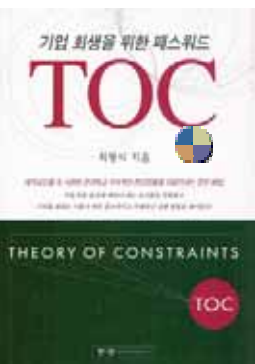

가

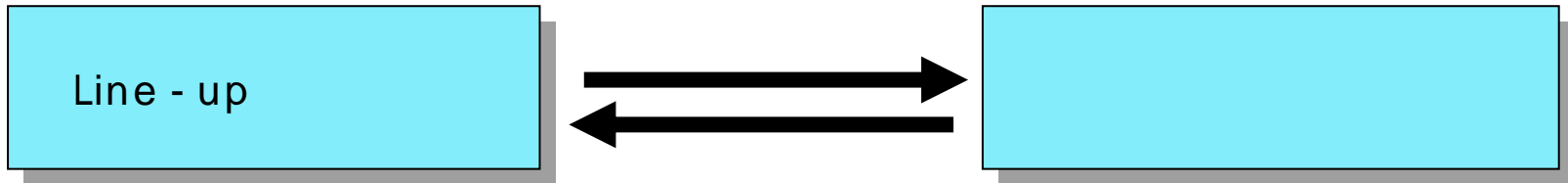

가

가

가

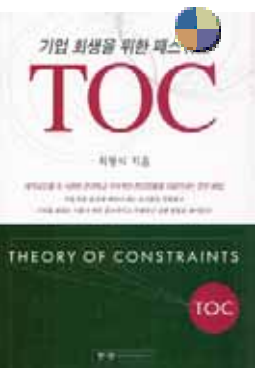

EC

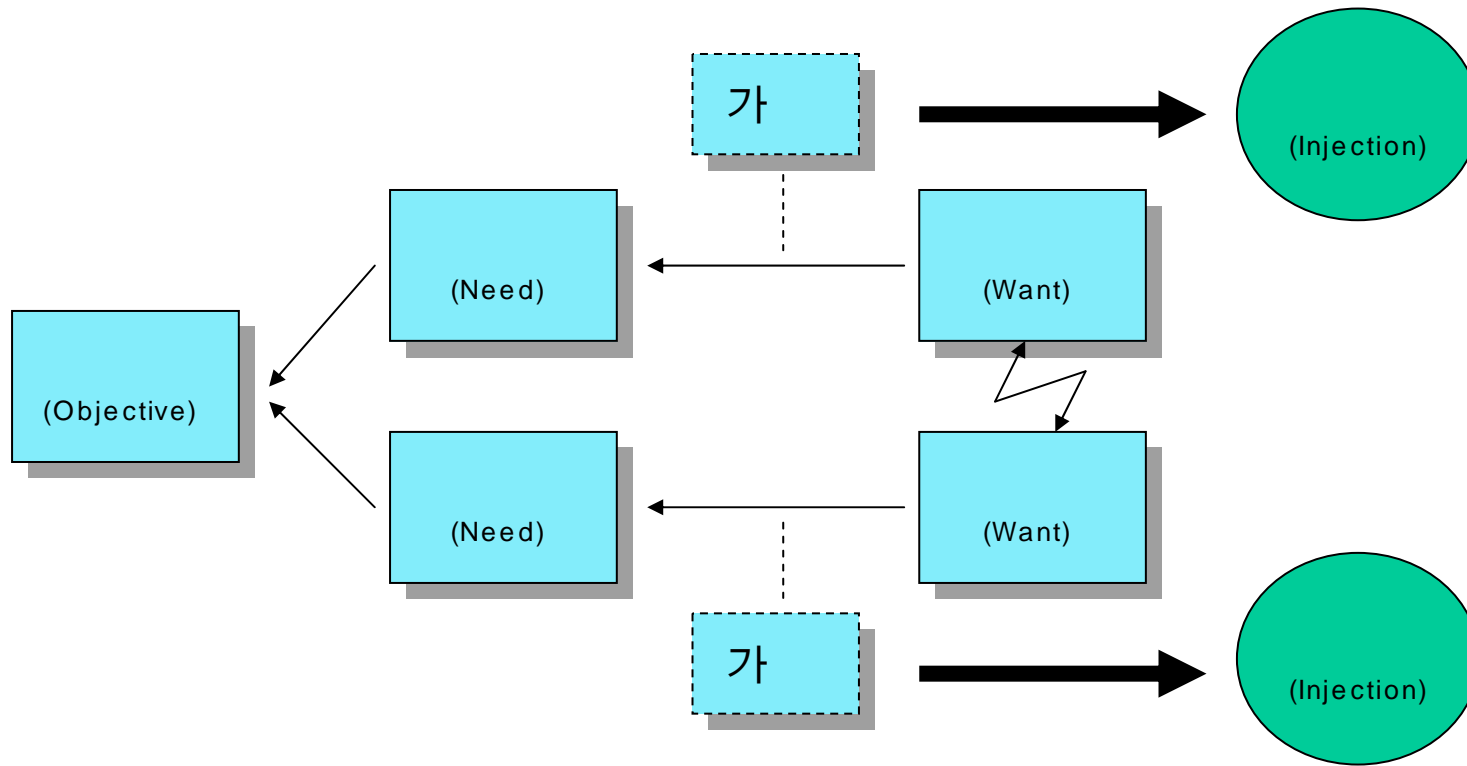

EC(Evaporating Cloud ;)

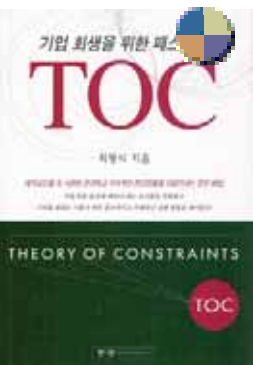

EC

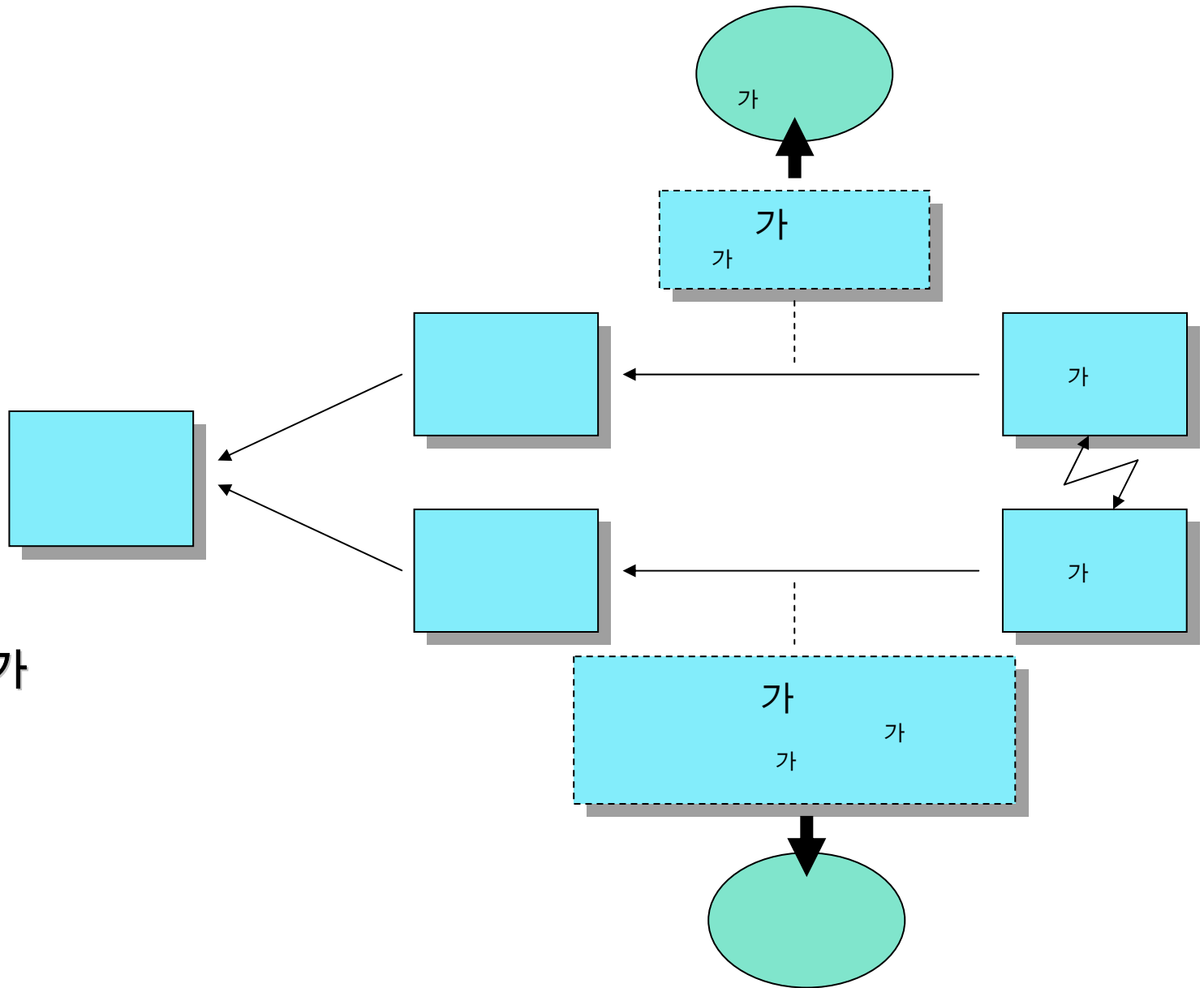

EC 가

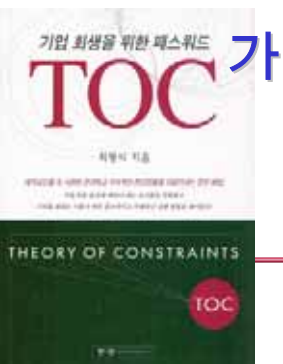

EC

EBOQ

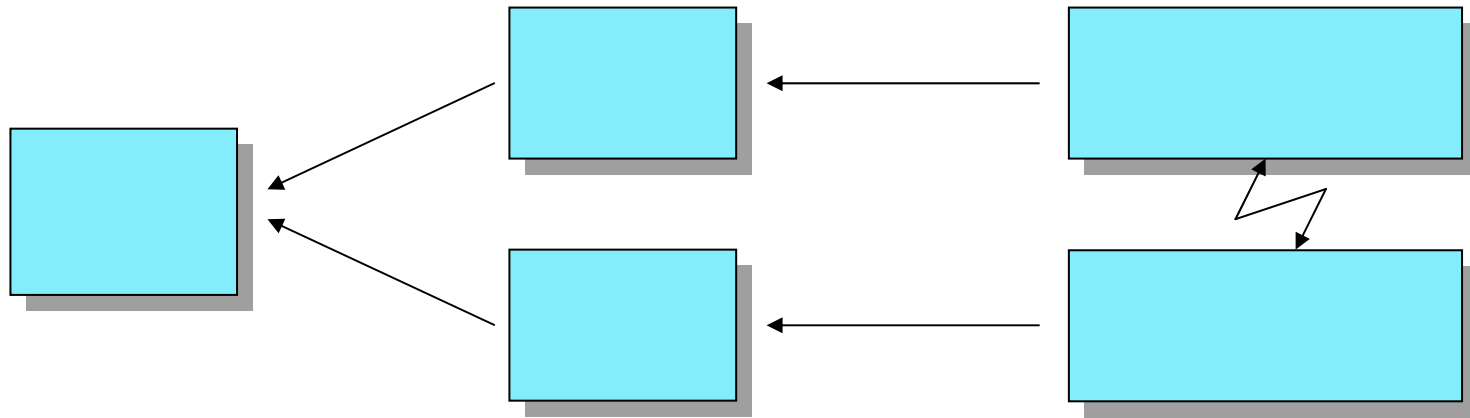

EC

가

, 가

EBOQ(Economic Batch Quantity ;)

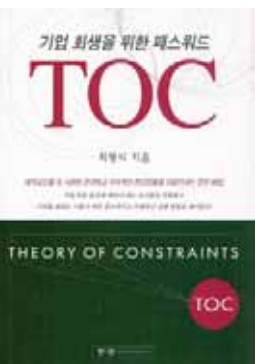

EC

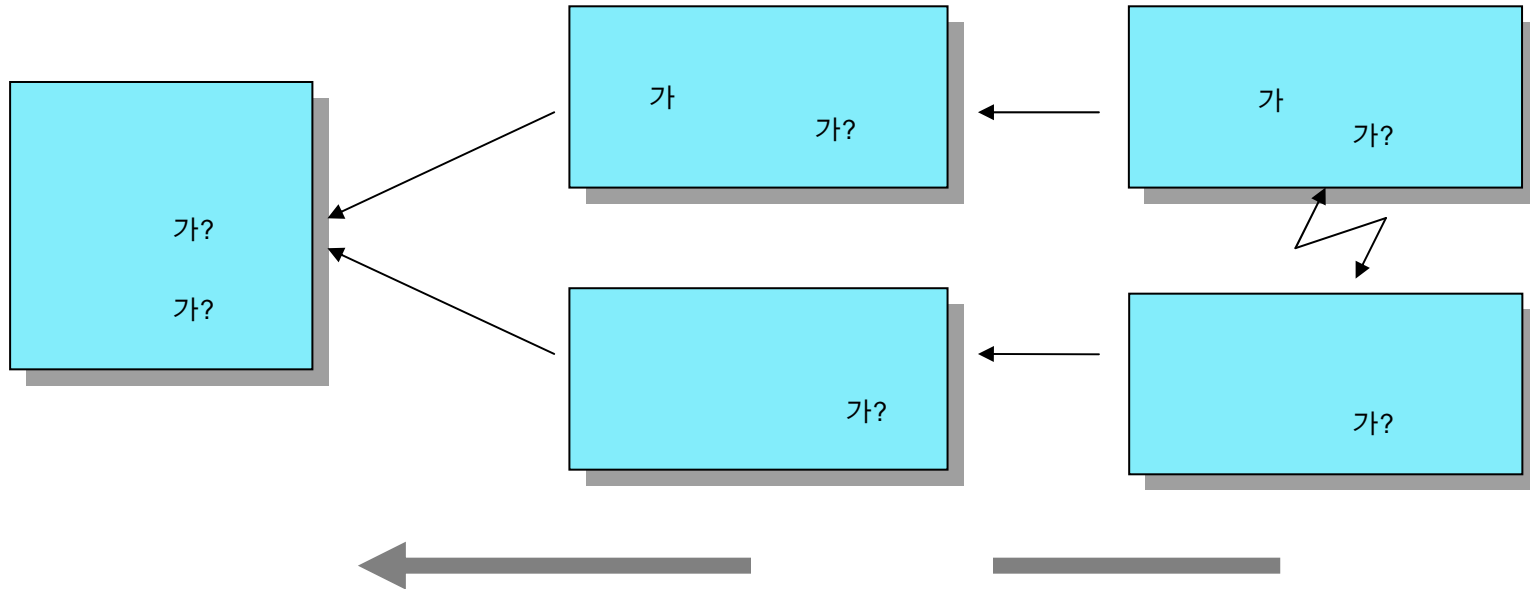

EC

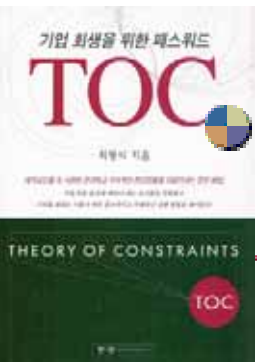

EC

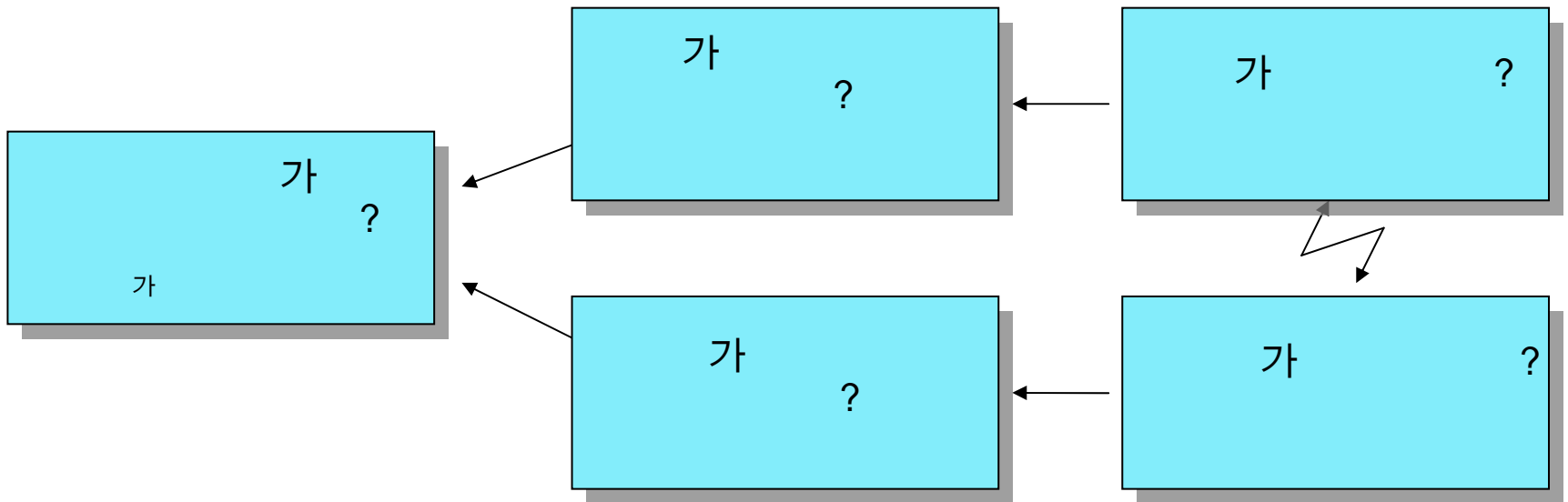

가

가

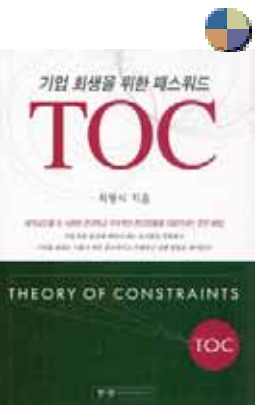

EC

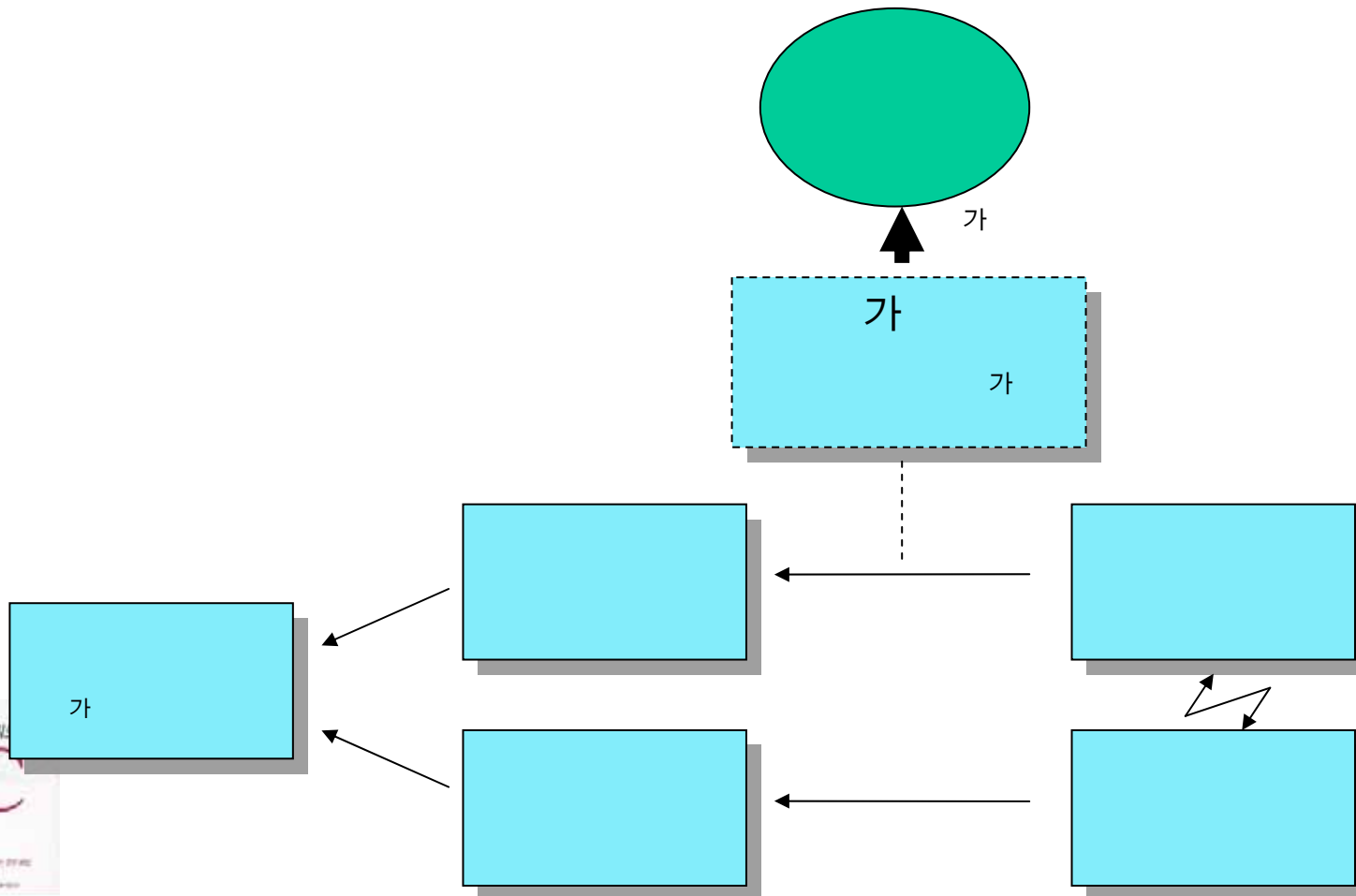

EC

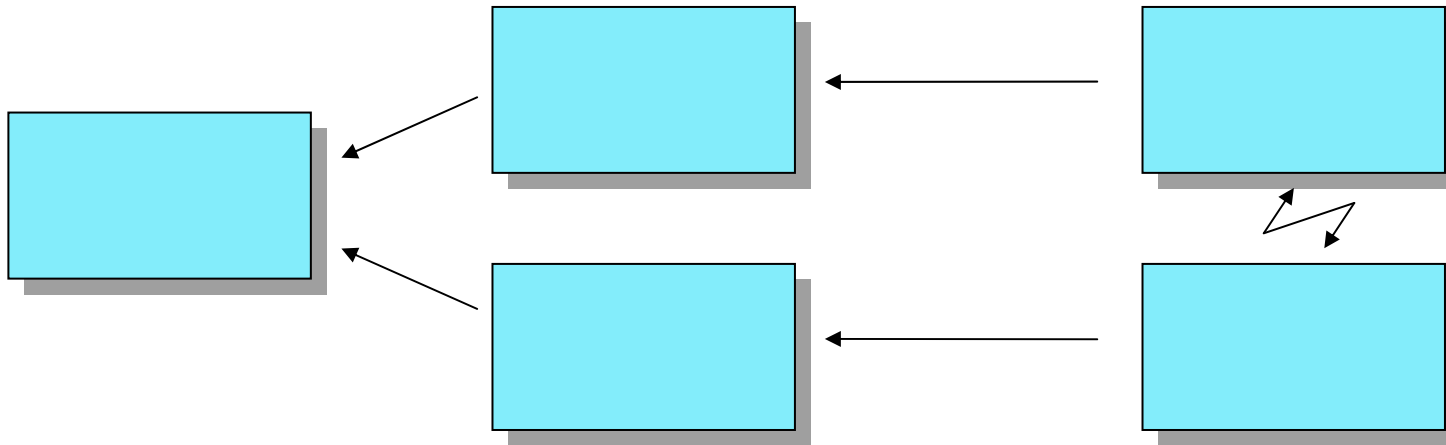

가

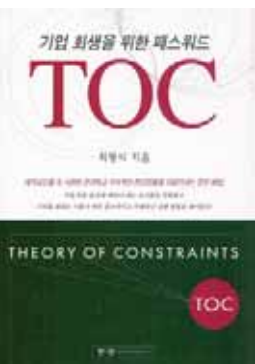

EC

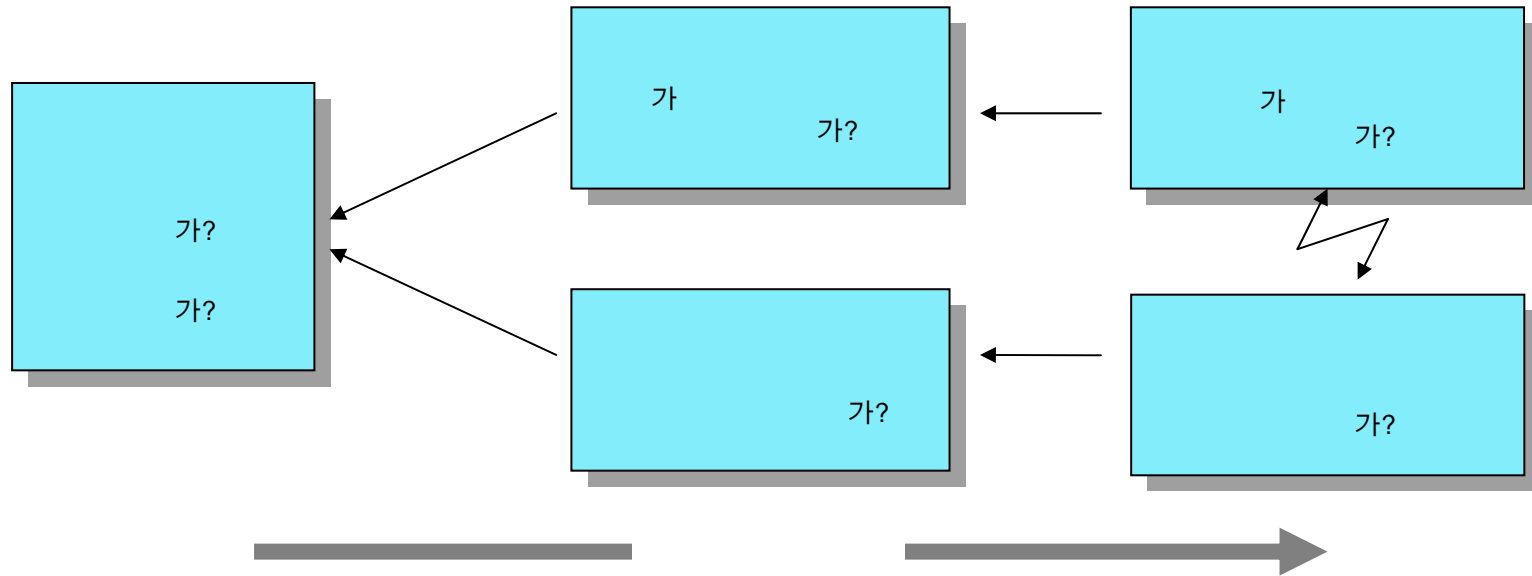

가

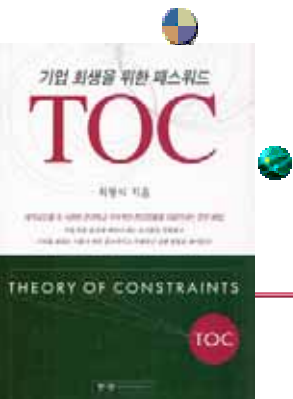

FRT

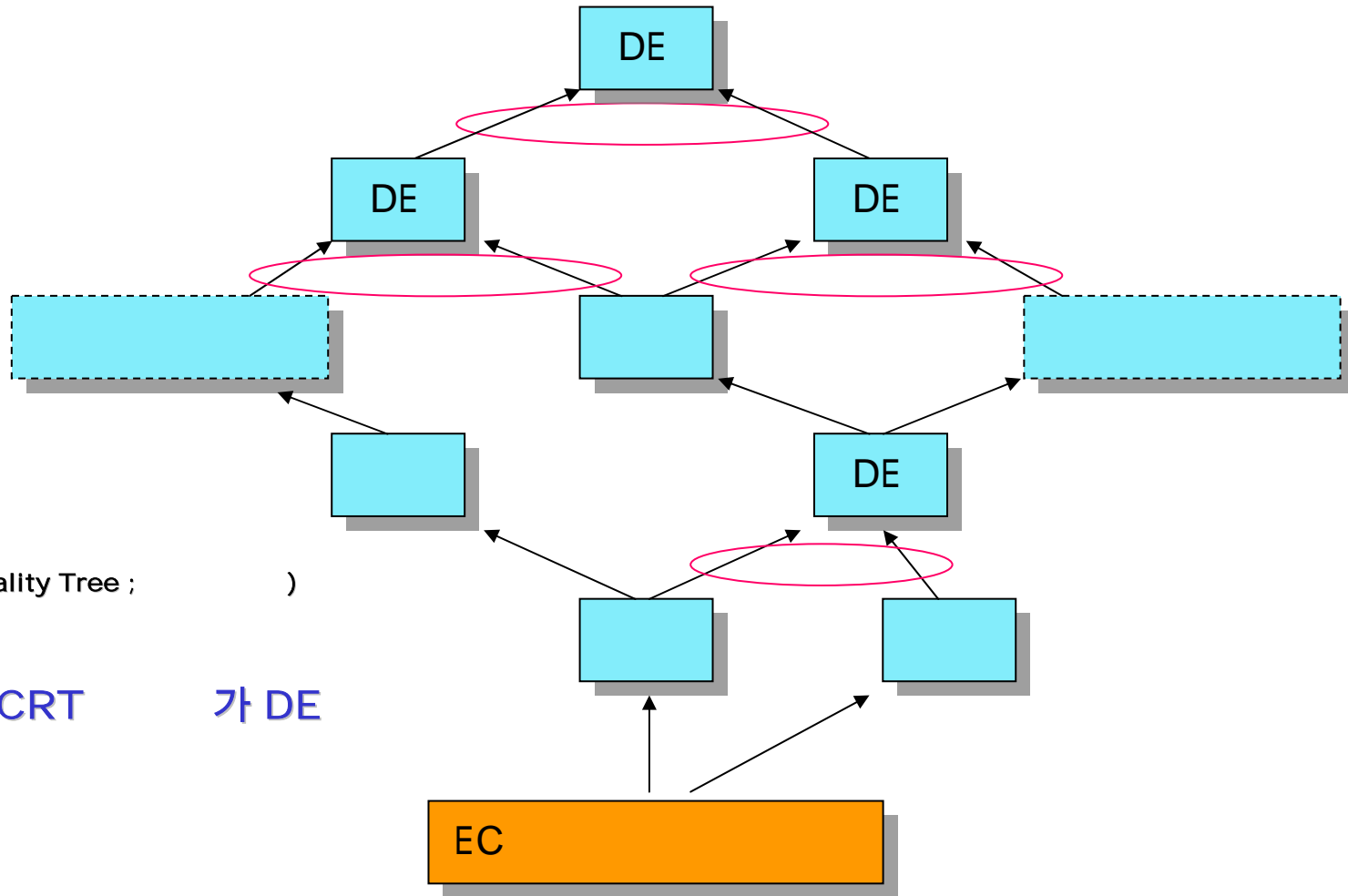

 **FRT** (Future Reality Tree ;)

 **EC**

, CRT 가 DE 가

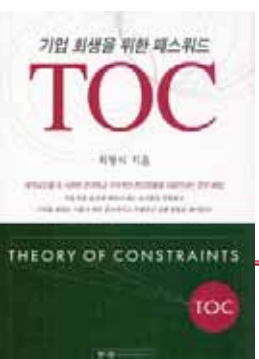

NBR : 가

가?

 **NBR** (Negative Branch Reservation ;

가)



가

 **NBR**



, EC



,



, NBR

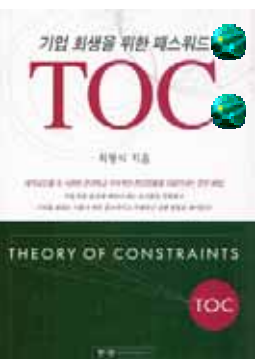

NBR

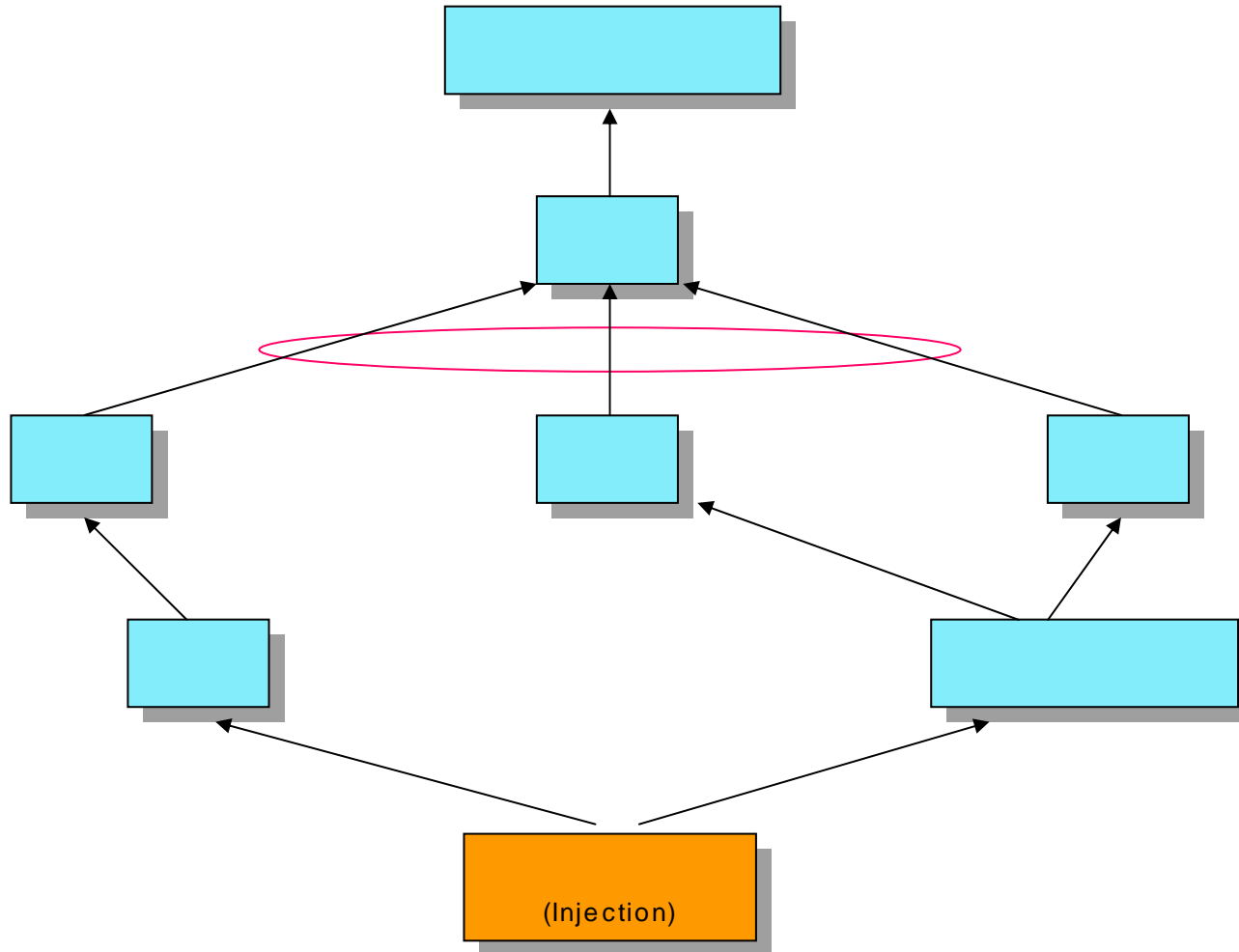

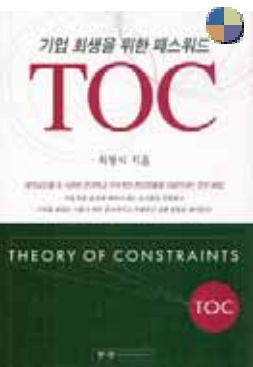
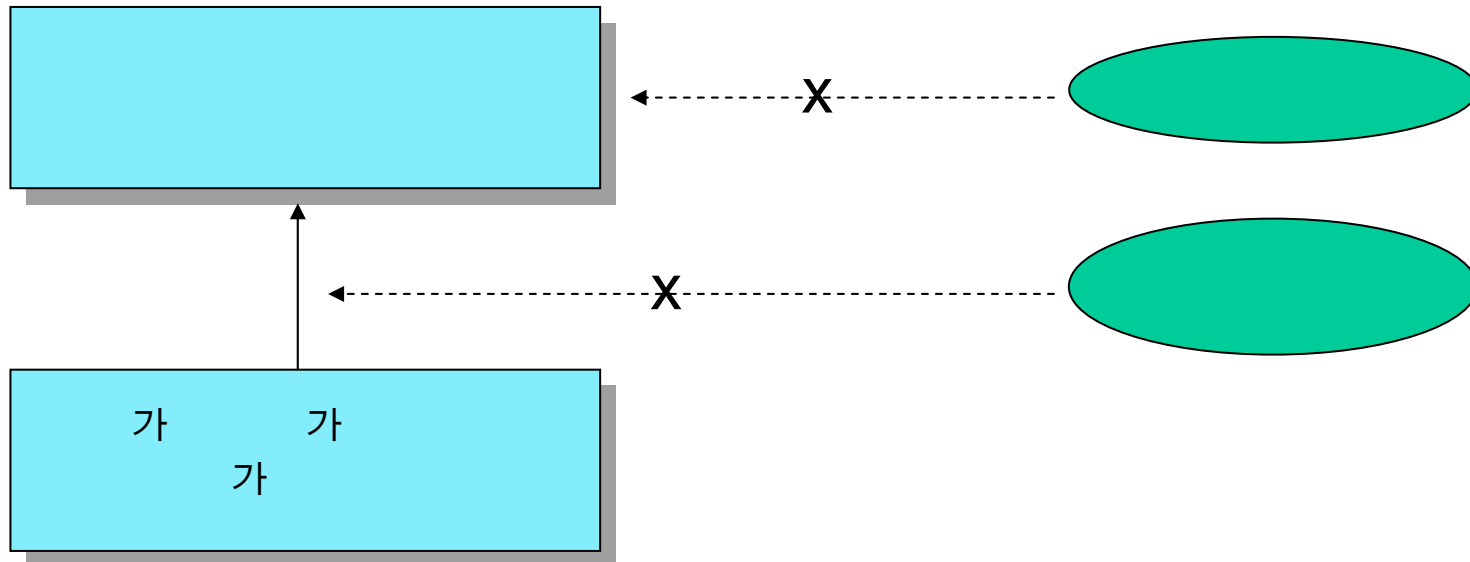

' 가 가 가 가 가 가 가 가 '

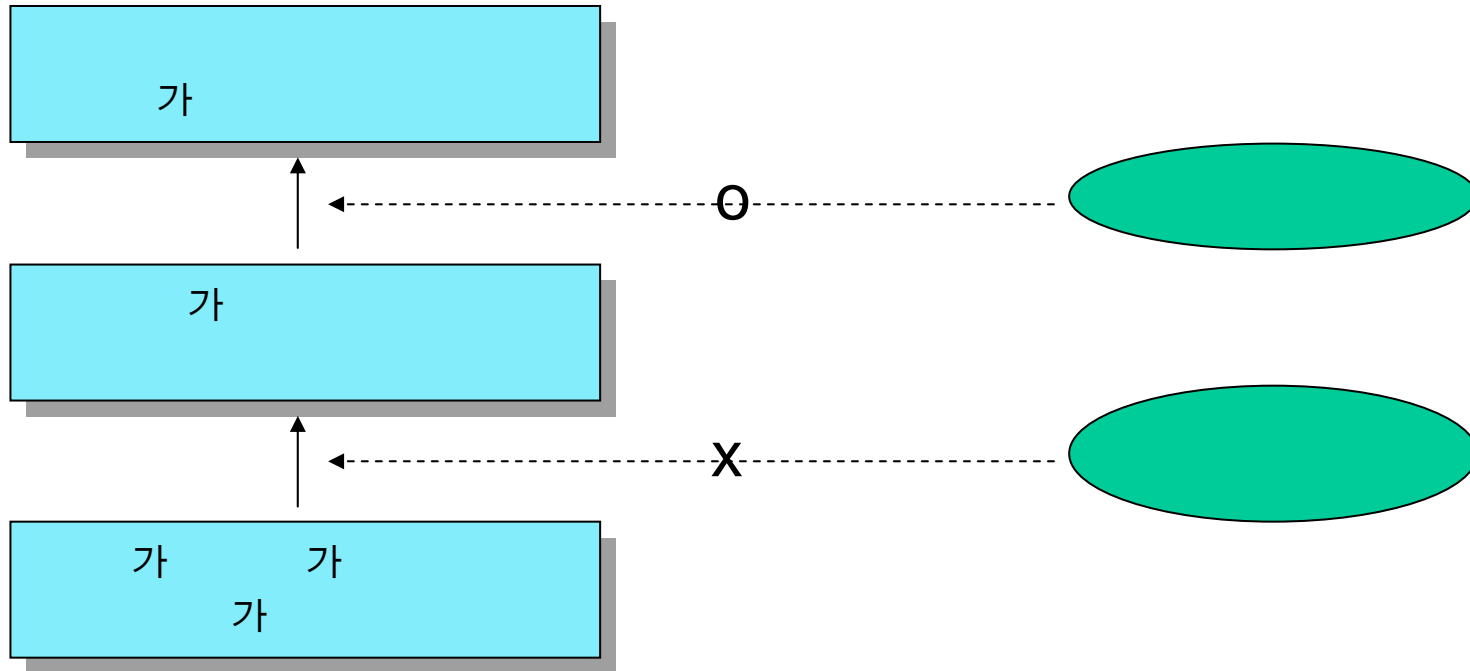

가

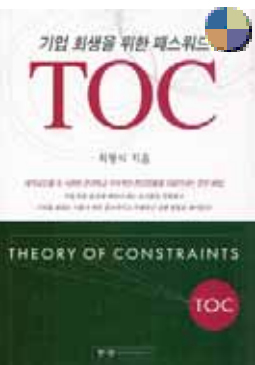

NBR

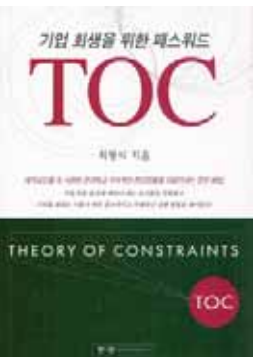
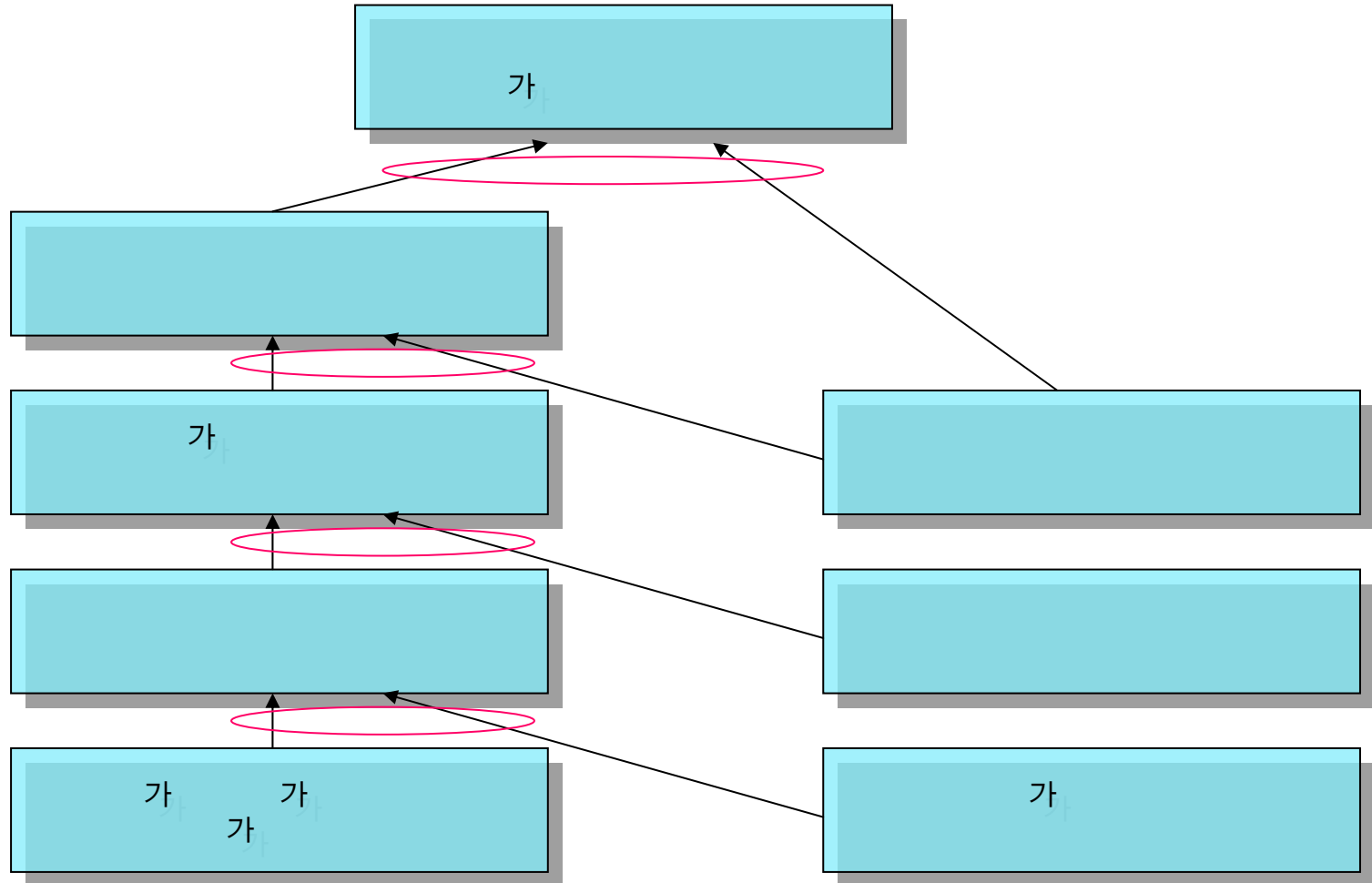

EC

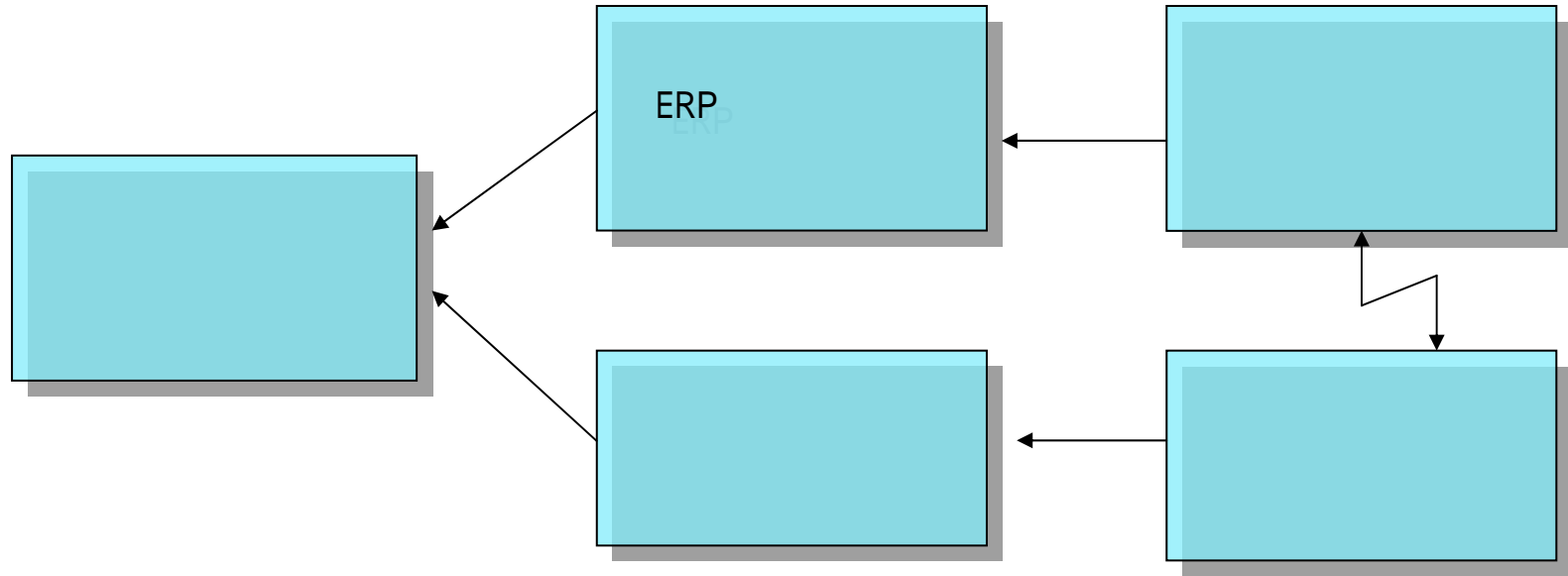

● ERP

, , 가



● ERP
● ERP

, 가 , ,



NBR

ERP

● NBR

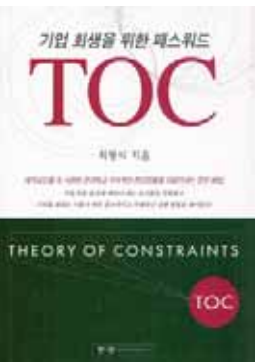
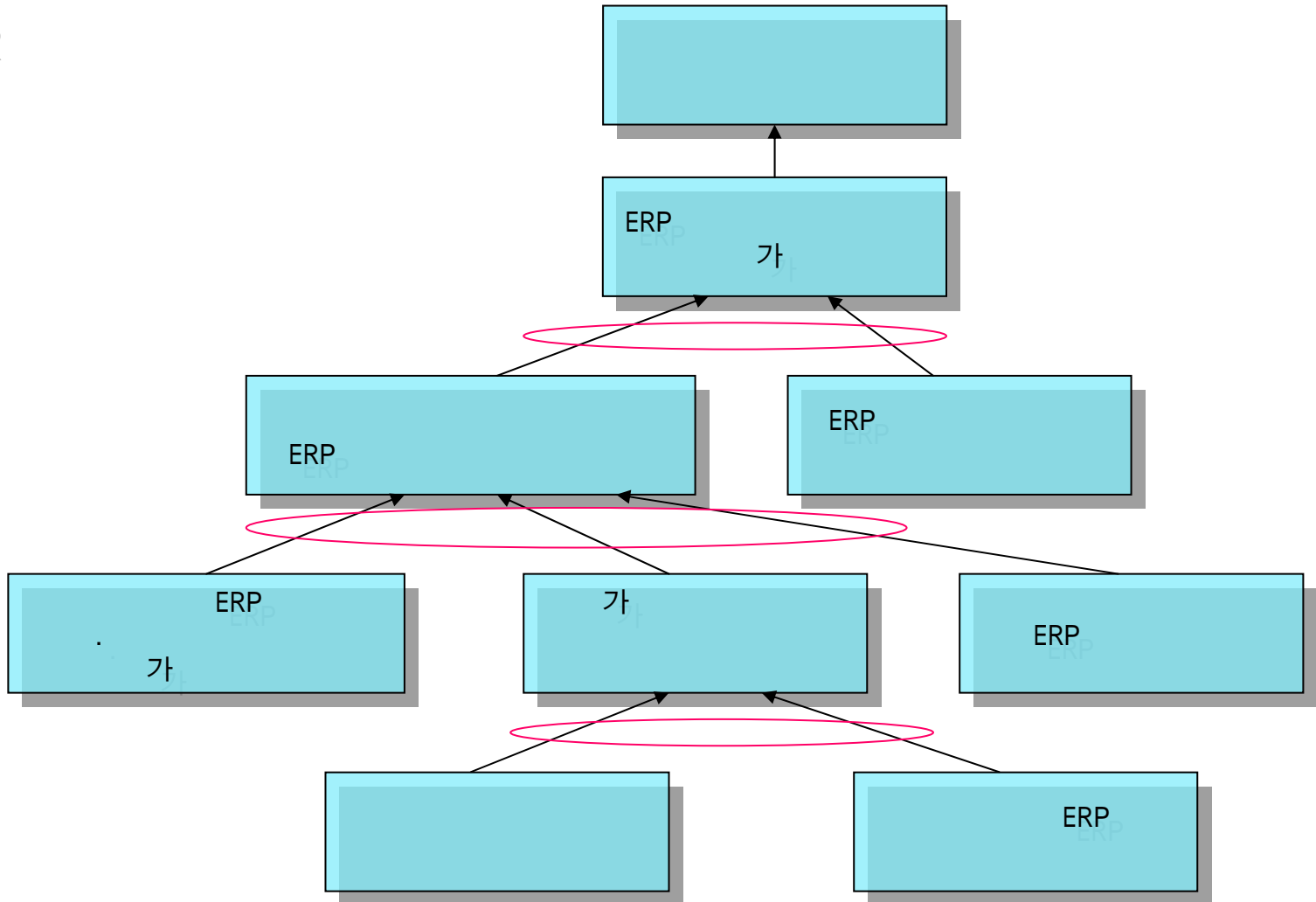

PT



 (Prerequisite Tree ;)







1 ,

가



2 ,



3 ,

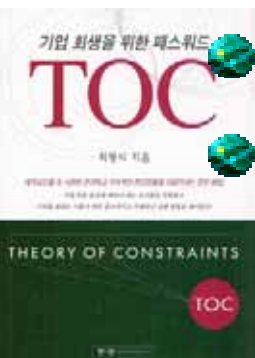

PT

가
가
가
가

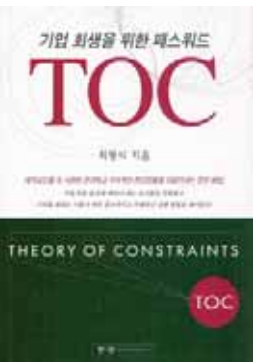
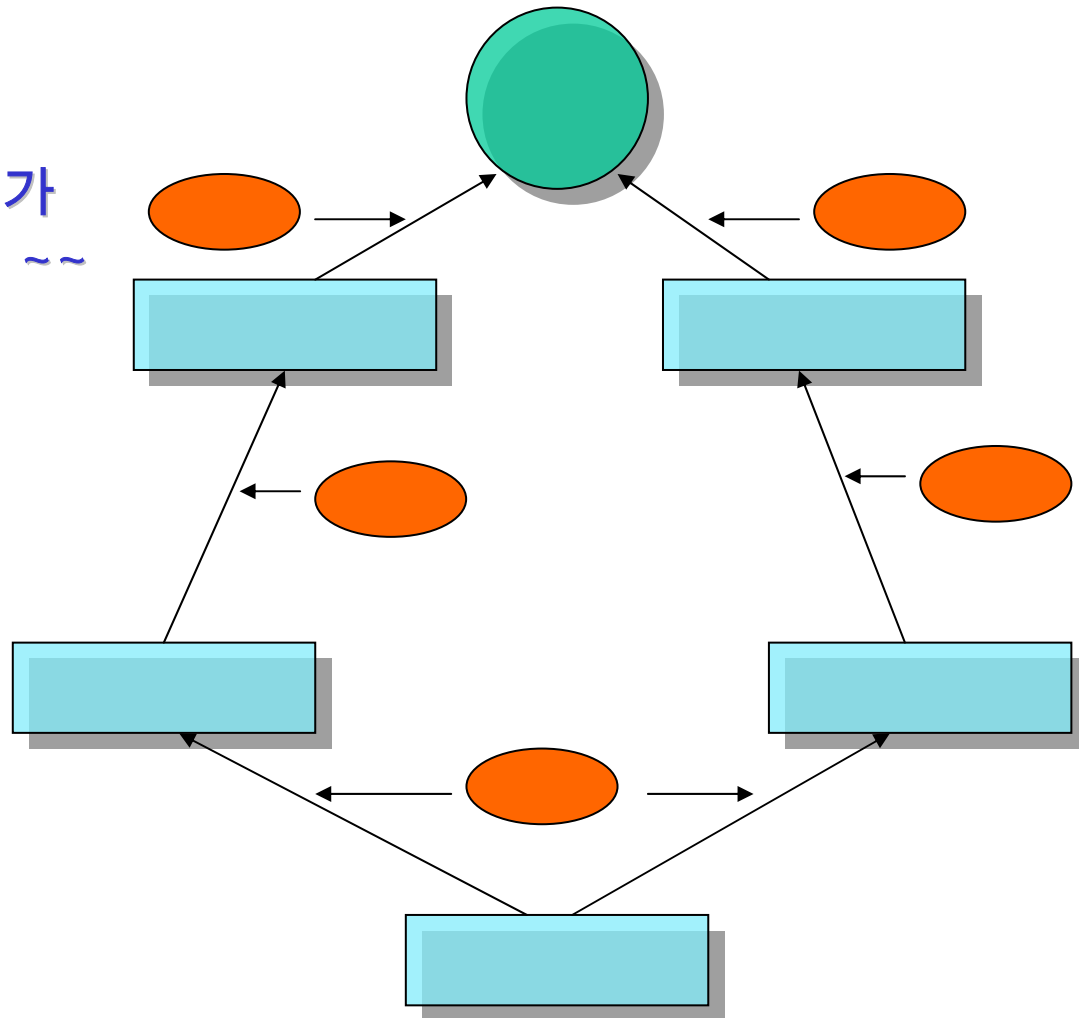

PT



.....
.....



()

1.
2.
3.
4.

1.
2.
3.
4.

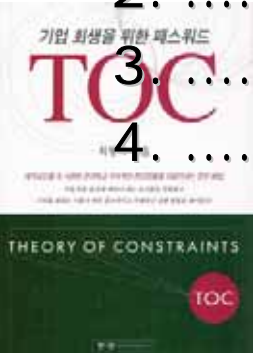

TT



 TT (Transition Tree ;)

 PT

 TT

-  1.
-  2.
-  3.
-  4.
-  5.

가? -

가? -

가? -

가?

가?

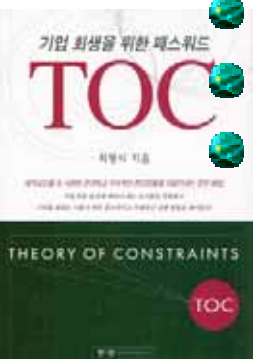

TT

TT

TT

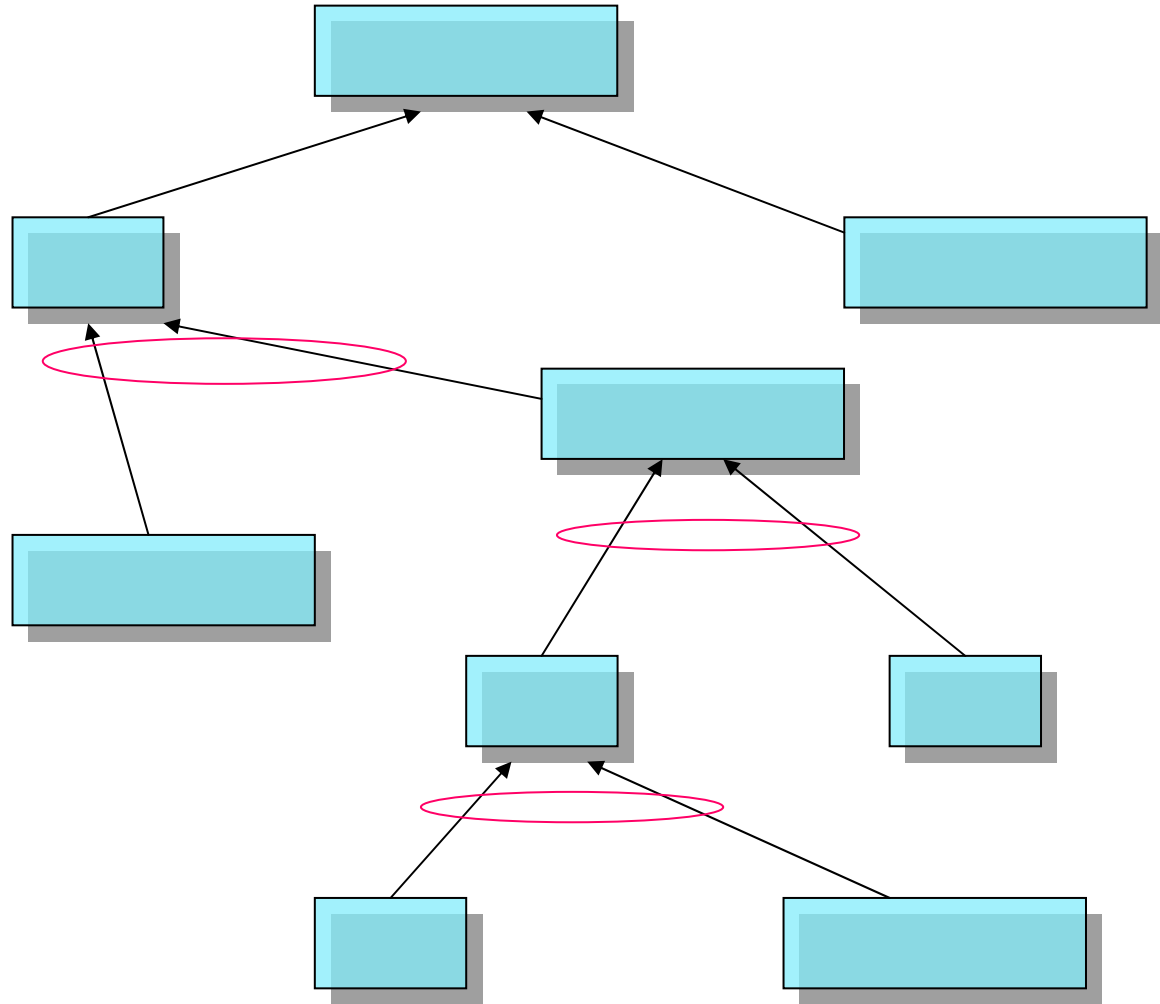

TT

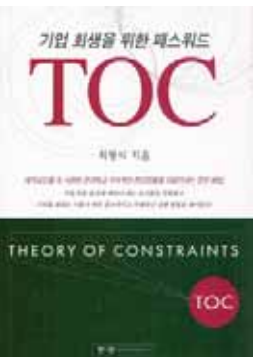
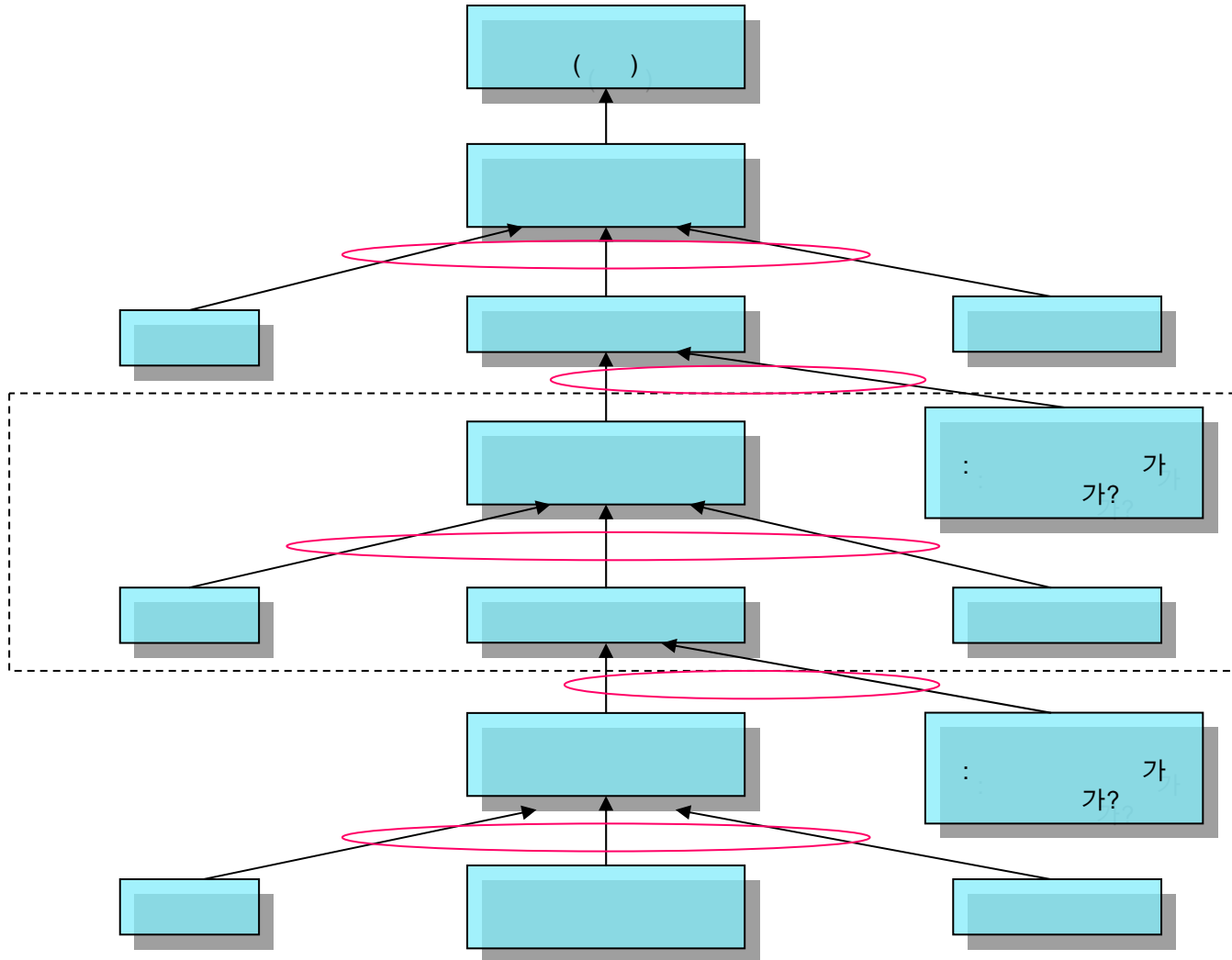

TP

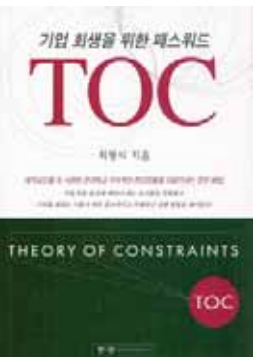
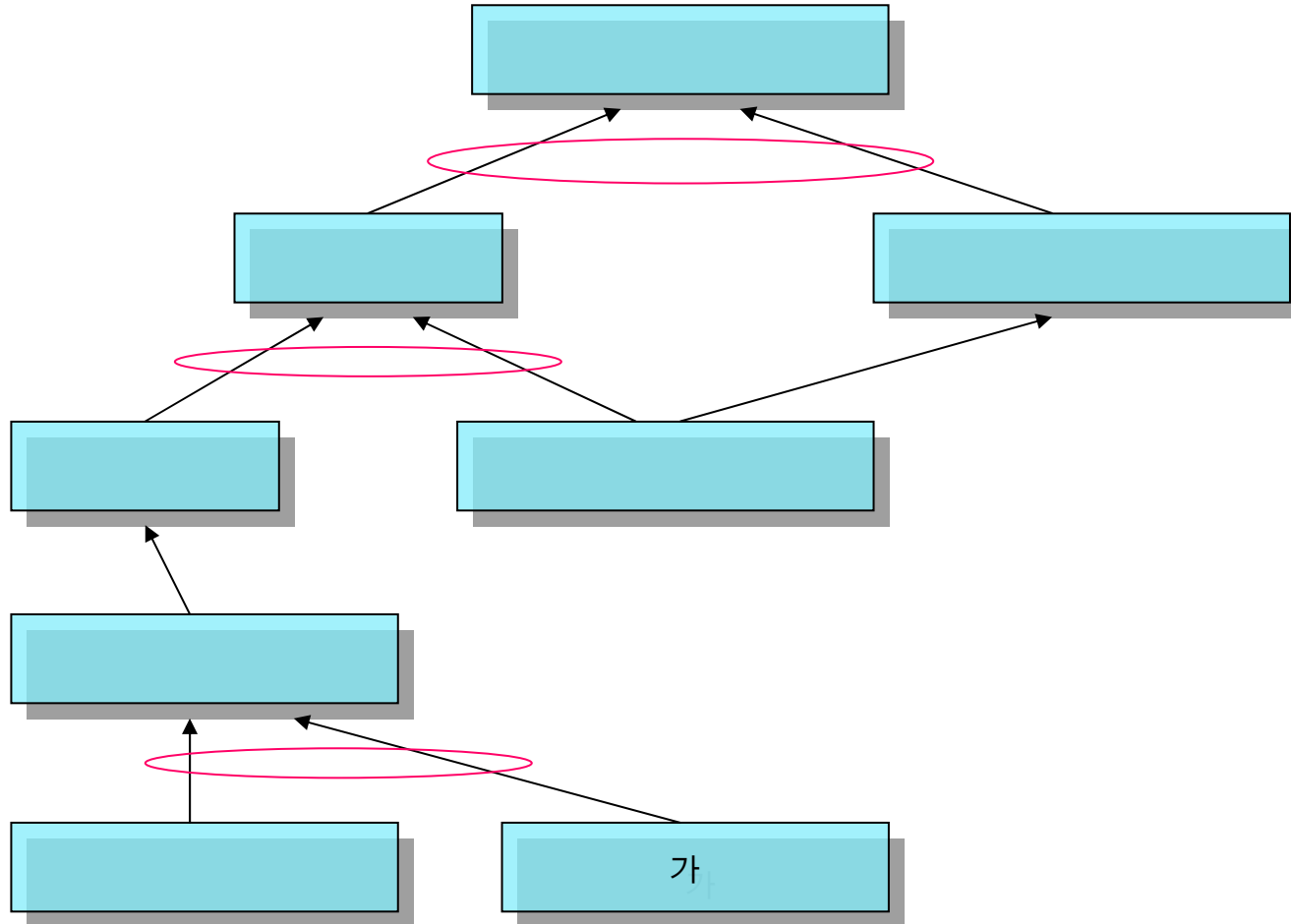

CRT

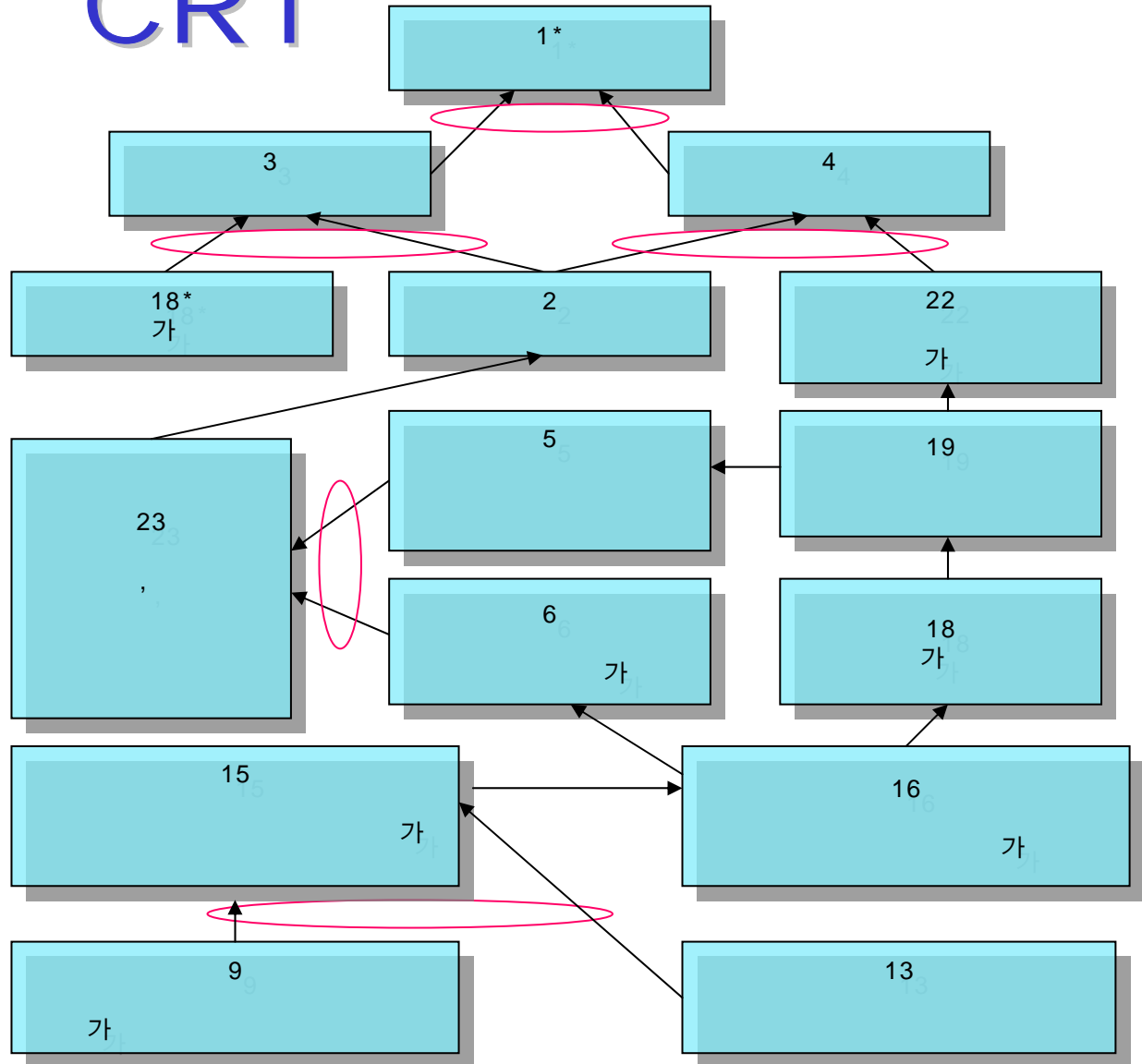

가 가

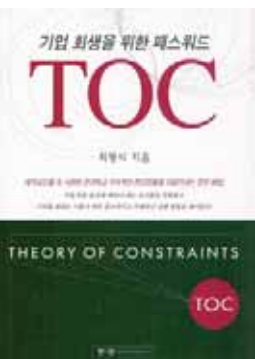

EC

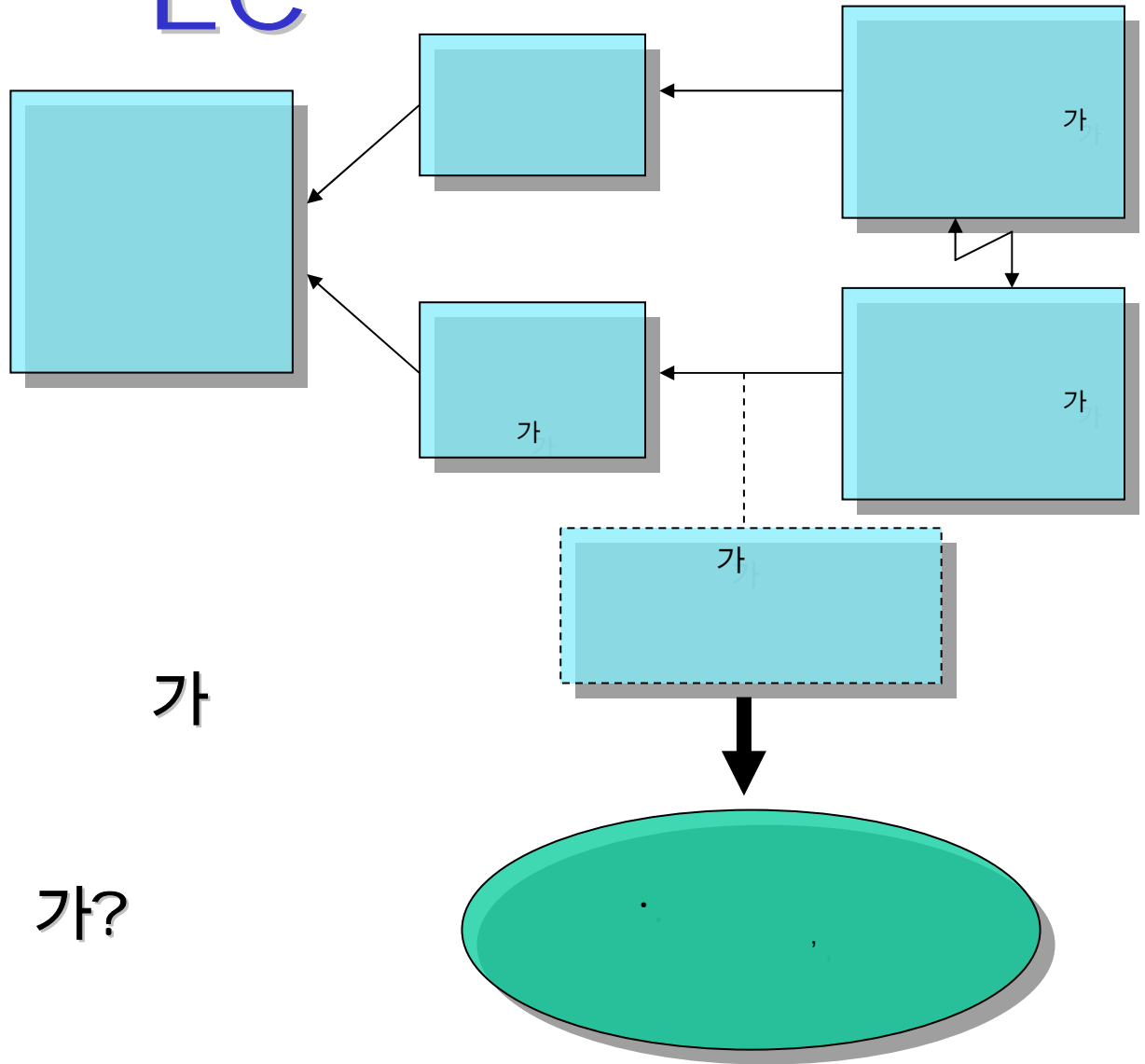

가

가?

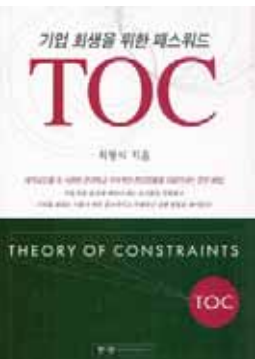

FRT

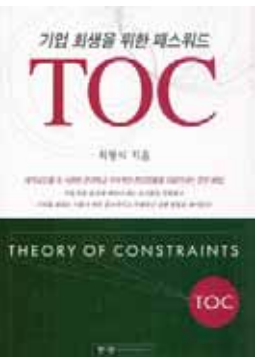
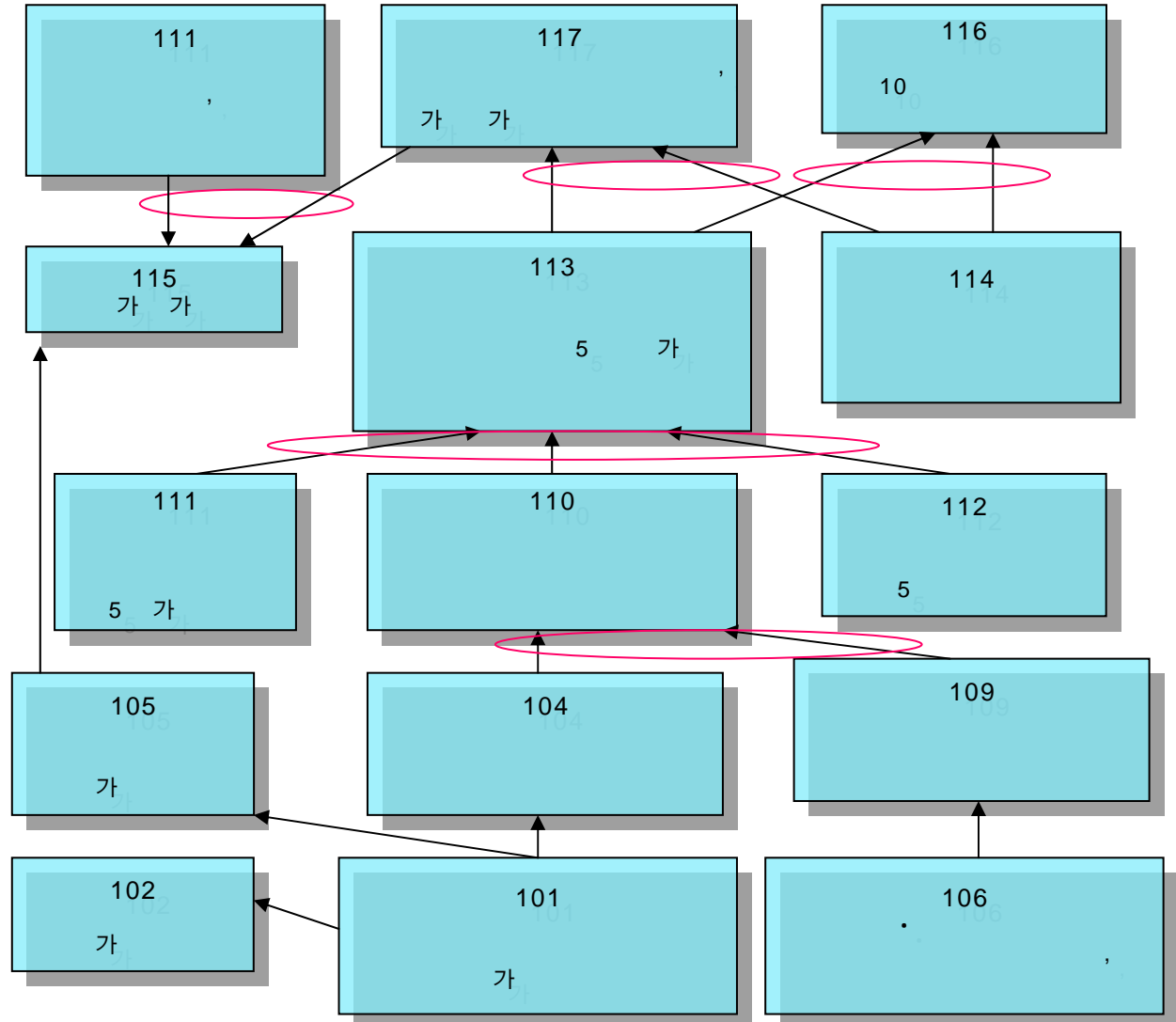

NBR

가

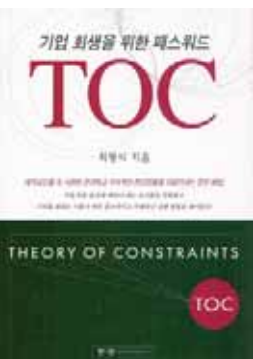
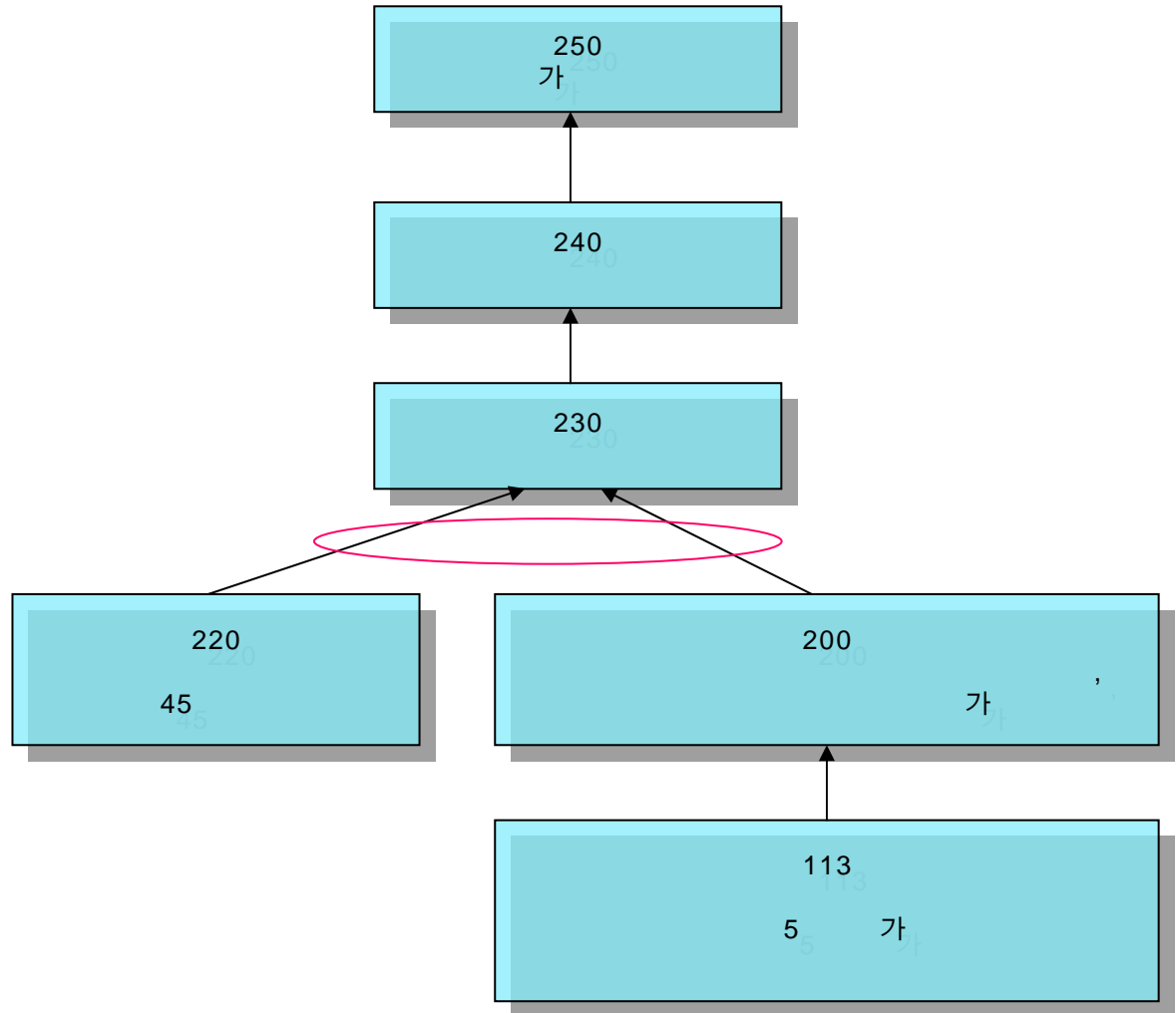

FRT

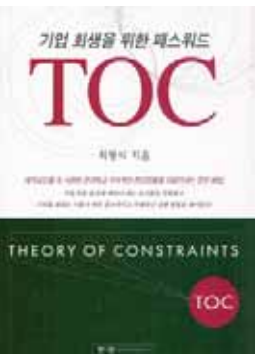
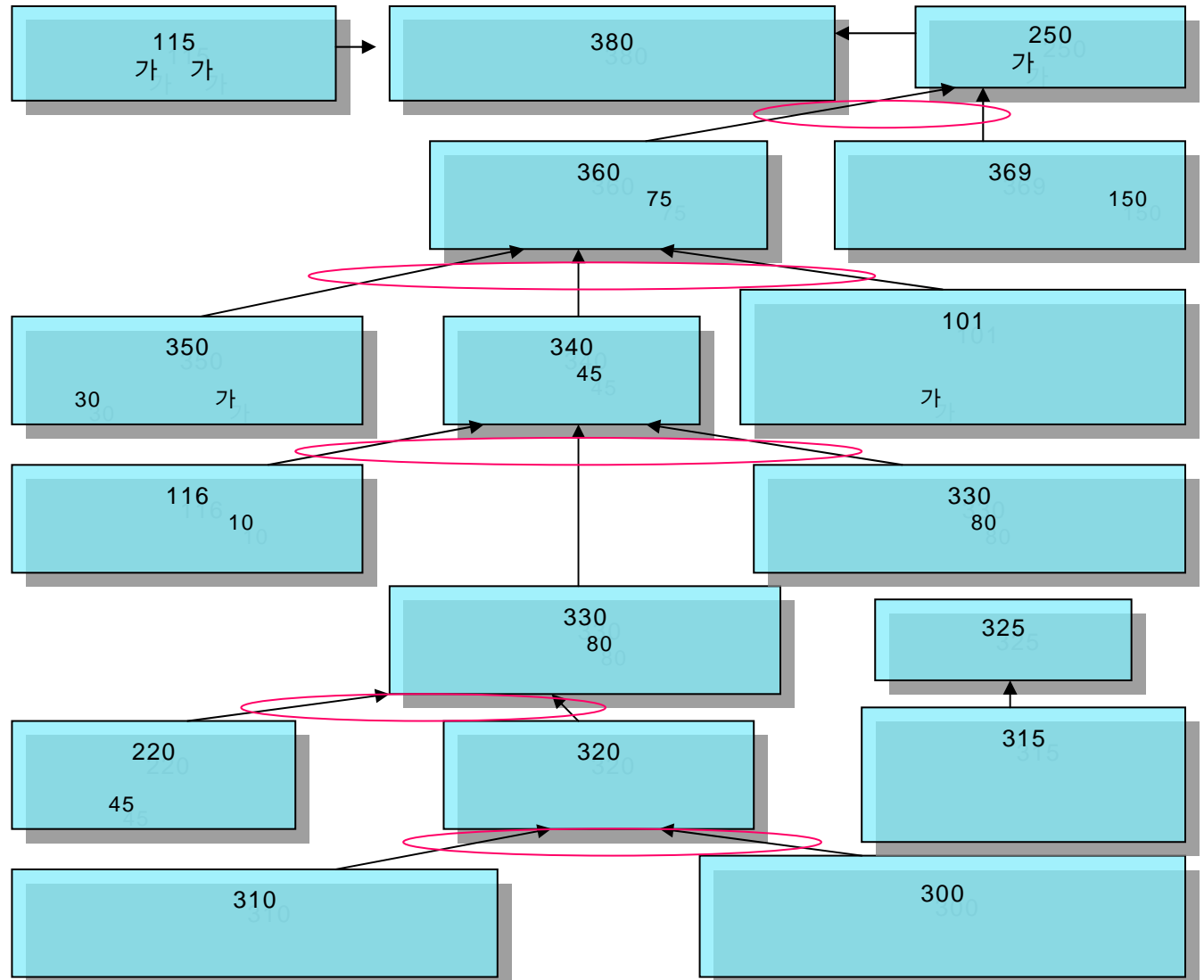

FRT

